INSTRUCTION MANUAL

Plasma Display Electric Pop-Up Lift (PUL)

Your Plasma Display Electric Pop-Up Lift is designed for installation in furniture or cabinets. Display mounting is made easy using the Q-latch mounting system and your PUL provides a smooth, quiet and reliable lift for your display.

The versatile Q-latch system not only makes mounting safe and easy, it makes changing display makes and models quick and inexpensive. Simply install the PSB mounting bracket designed specifically for the display and mount it on the PUL.

Superior performance and dependability are designed into your PUL. The lift is made using heavy duty steel and aluminum extrusion construction. All electrical components are UL/TUV listed and the use of low voltage, solid state circuitry controls ensure safety and reliability.



BEFORE YOU BEGIN

- **CAUTION:** To prevent damage to the PUL, which could affect or void the Factory warranty, thoroughly study all instructions and illustrations before you begin to install or operate the unit. Pay particular attention to the “Important Precautions” on Page 1.
- If you have any questions about this installation, contact Chief Manufacturing at 1-800-582-6480.



IMPORTANT WARNINGS and CAUTIONS!

- WARNING:** A **WARNING** alerts you to the possibility of serious injury or death if you do not follow the instructions.
- CAUTION:** A **CAUTION** alerts you to the possibility of damage or destruction of equipment if you do not follow the corresponding instructions.
- **WARNING:** Be aware during the installation that this is a motorized device, and there are pinch points for people and for electrical wiring.
 - **WARNING:** Be aware of the potential for personal injury or damage to the unit if it is not adequately mounted. The lift (without a projector) weighs approximately 150 lbs (68 kg).
 - **WARNING:** Be sure the lift is installed square and parallel in all dimensions to avoid damage to the lift. Avoid stressing the unit at any time during installation.
 - **WARNING:** Electrical outlets must be installed by a qualified electrician. Follow all electrical codes.
 - **CAUTION:** Vertical travel adjustment must always be made with the shelf in the middle of travel position and the power switch OFF.
 - **CAUTION:** The unit must always be able to reach its own limit switches and turn itself off.
 - **CAUTION:** Test the unit for shipping damage. See “Inspect and Test the unit before installing,” on page 5.

TOOLS REQUIRED FOR INSTALLATION

- Phillips screwdrivers, No. 1 and No. 2
- Electric drill and 17/64” drill bit
- Socket set with extension
- Allen wrench set

NOTE: Other tools may be required depending on the method of installation.

WEIGHT, SIZE, AND VERTICAL TRAVEL SPECIFICATIONS

See Table 1 on page 3 for the weight, size, and vertical travel specifications of your specific model.

1. Determine size and weight of the equipment to be lifted.
2. Determine the vertical travel height required for presentation viewing.

CONTENTS

WEIGHT, SIZE, AND VERTICAL TRAVEL SPECIFICATIONS	3
DIMENSIONAL DRAWING	4
INSPECT AND TEST THE UNIT BEFORE INSTALLING	5
Inspect The Unit	5
Test The Unit	5
PREPARE THE FURNITURE/CABINET AND INSTALL THE LIFT	6
General Guidelines	6
Prepare the Furniture/Cabinet	6
Furniture Opening Finish Piece Options	6
Extended Position Finish Piece Option	6
Retracted Position Finish Piece Option	7
Install the PUL into the Cabinet	9
INSTALL THE DISPLAY ON THE LIFT	10
Attach Brackets to the Display	10
Mount the Display	10
ADJUSTMENTS	11
Width Adjustment	11
Adjust Vertical Travel	11
WIRING	13
Pushbutton	13
Extend and Retract Terminals to be Triggered by Separate Dry Contacts	13
Remote (RC-10)	15
12 Volt Out Supply	17
24 Volt Out Supply	17
Two Dry Contact Closures	17
Low Voltage Sensing	17
TROUBLESHOOTING	19

- Determine the inside dimensions available in your furniture/ cabinet (see Table 2, "Adjustable Width").

Table 1: Weight, Size, and Vertical Travel

Model	Lift Capacity	Outside Dimensions	Max. Equipment Size HxWxD	Vertical Travel
PUL4228	230Lbs 104.3Kgs	33.75"x7.7" (857.3mmx195.6mm)	25.5"x54.125"x6.5" (647.7mmx1374.8mmx165.1mm)	28" 711.2mm
PUL4233	230Lbs 104.3Kgs	38.75"x7.7" (984.3mmx195.6mm)	30.5"x54.125"x6.5" (774.7mmx1374.8mmx165.1mm)	33" 838.2mm
PUL4239	230Lbs 104.3Kgs	44.75"x7.7" (1136.7mmx195.6mm)	36.5"x54.125"x6.5" (927.1mmx1374.8mmx165.1mm)	39" 990.6mm
PUL4245	230Lbs 104.3Kgs	50.75"x7.7" (1289.1mmx195.6mm)	42.5"x54.125"x6.5" (1079.5mmx1374.8mmx165.1mm)	45" 1143.0mm
PUL4251	230Lbs 104.3Kgs	56.75"x7.7" (1441.5mmx195.6mm)	48.5"x54.125"x6.5" (1231.9mmx1374.8mmx165.1mm)	51" 1295.4mm
PUL4257	230Lbs 104.3Kgs	62.75"x7.7" (1593.9mmx195.6mm)	54.5"x54.125"x6.5" (1384.3mmx1374.8mmx165.1mm)	57" 1447.8mm

Table 2: Adjustable Width

Model	Outside	Inside
PUL4228	44.125" to 56.125" 1120.8mm to 1425.6mm	42.125" to 54.125" 1070.0mm to 1374.8mm
PUL4233	44.125" to 56.125" 1120.8mm to 1425.6mm	42.125" to 54.125" 1070.0mm to 1374.8mm
PUL4239	44.125" to 56.125" 1120.8mm to 1425.6mm	42.125" to 54.125" 1070.0mm to 1374.8mm
PUL4245	44.125" to 56.125" 1120.8mm to 1425.6mm	42.125" to 54.125" 1070.0mm to 1374.8mm
PUL4251	44.125" to 56.125" 1120.8mm to 1425.6mm	42.125" to 54.125" 1070.0mm to 1374.8mm
PUL4257	44.125" to 56.125" 1120.8mm to 1425.6mm	42.125" to 54.125" 1070.0mm to 1374.8mm

DIMENSIONAL DRAWING

See Table 1 on page 3 for outside adjustable width, dimension "H" and dimension "W".

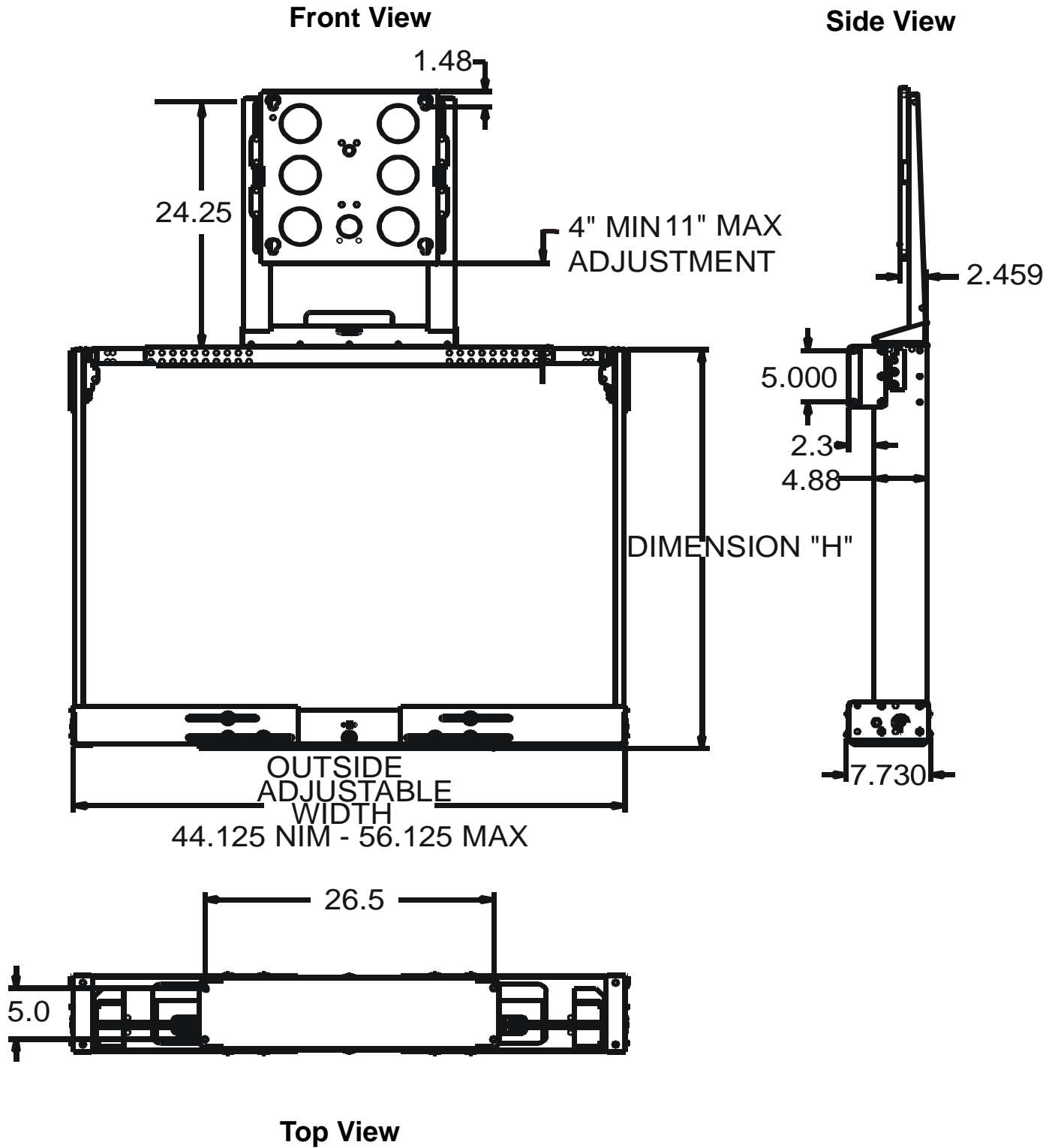

INSPECT AND TEST THE UNIT BEFORE INSTALLING

Inspect The Unit

1. Carefully inspect the Plasma Display Electric Pop-Up Lift (PUL) for shipping damage. If any damage is apparent, call your carrier claims agent and do not continue with the installation until the carrier has reviewed the damage.

NOTE: Read all assembly instructions before starting assembly.

2. Carefully inspect PUL components for damage, checking vertical extrusion arms to make sure they are parallel.

IMPORTANT: Before mounting the lift in the furniture/cabinet, make the following tests to be sure that it operates properly and has not been damaged in shipping.

Test The Unit

1. Set the PUL on a clean, level surface.
2. Connect the motor control box to the control circuit housing (see Figure 1, Figure 2, and Figure 3).
3. Install two terminal blocks in control box (see Figure 2).

NOTE: The lift is supplied with a momentary push button on the end of a cable to help you pretest the operation.

3. Connect the momentary push button (provided) cable leads to terminals #6 and #1 and add a jumper wire (provided - electrical wire about 4 in. long with 1/4 in. stripped at each end) between terminals #2 and #5 on the same terminal block (see Fig. 4).
4. Plug the lift's power cord (see Figure 3) into a 110V 60 Hz or 220V 50 Hz (as appropriate) 15-amp outlet.

NOTE: The lift draws approximately 1.5 amps.



WARNING: Be aware during the installation that this is a motorized device, and there are pinch points for people and for electrical wiring. Keep hands and electrical wiring away from internal components of the mechanism

5. Operate the lift much like a garage-door opener: press the button when the lift is at its "bottom" position and it will move "up"; press again when it is at its "top" position and it will move "down"; press while moving and it will stop.

Use the push button to check that the lift runs to the top and bottom of its travel without any interference that might indicate damage during shipment.

6. Unplug the lift's power cord.

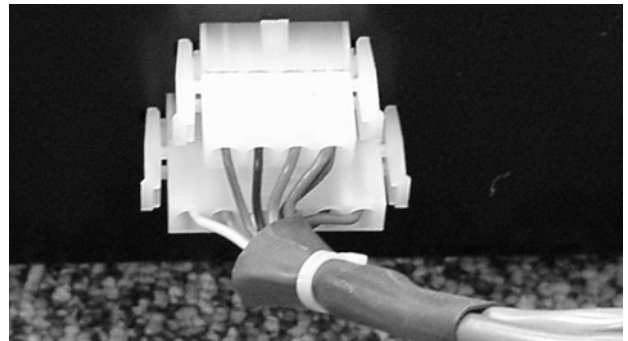

Figure 1. Connection to Housing

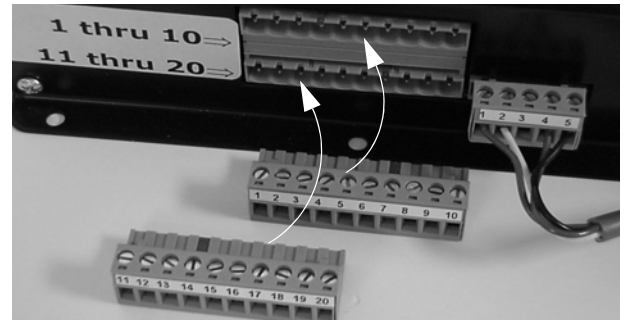

Figure 2. Front Connection to Control Box



Figure 3. Back Connection and Power Cord to Control Box

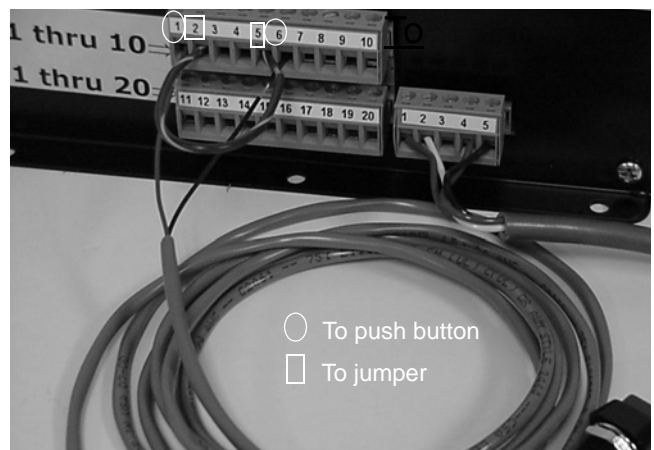

Figure 4. Test Wiring

PREPARE THE FURNITURE/CABINET AND INSTALL THE LIFT

Because of the wide variety of possible mounting situations, Chief Manufacturing can only provide general guidelines for lift installation. Study the following information carefully, and adapt it as necessary to fit your specific installation.

WARNING: Be especially aware of the weight of the unit, and the potential for personal injury or of damage to the unit if it is not adequately mounted. The lift (without a projector) weighs approximately 150 lbs (68 kg).

The “General Guidelines” below and the information on the following pages cover the most common mounting situations:

General Guidelines

- Compare the inside dimensions of the furniture/cabinet in which the lift will be installed with the dimensional requirements of your display and any additional space required for your application. Allow for movement of the lift and the display.

Prepare the Furniture/Cabinet



WARNNG: Be aware during the installation that this is a motorized device, and there are pinch points for people and for electrical wiring. Keep hands and electrical wiring away from internal components of the mechanism

1. Determine size and weight of display to be lifted. See “Weight, Size, and Vertical Travel” on page 3 for weight limitations.
2. Determine vertical travel height required for presentation viewing. See Table 1 for height limitations.

Furniture Opening Finish Piece Options

Because of the wide variety of possible mounting situations, Chief Manufacturing can only provide general guidelines for finish options. Study the following information carefully, and adapt it as necessary to fit your specific installation.

NOTE: Always leave access to the lift for maintenance purposes.

Extended Position Finish Piece Option

A finish piece, covering the opening when the unit is in the fully extended position, may be installed for estetic purposes. Using the material cut slight smaller than the opening size, install the finish piece as follows:

1. Measure the width of the finish piece.
2. Measure the distance between the verticle extrusion arms and subtract a nominal amount for clearance.

CAUTION: Failure to allow clearance for the finish piece to retract to the fully lowered position may result in damage to the finish piece, damage to the lift, and damage to the plasma.

3. Make sure the finish piece measured in step 1 is smaller than the clearance distance measured in step 2 and note any cord management access holes that may be necessary.
4. Measure the thickness of the finish piece, add this thickness to the length of the five capscrews used to secure the plasma mounting assembly when a backing is not used, and obtain the five longer 3/8-16 capscrews for assembly with backing.
5. Place the finish piece on the shelf, making sure it is correctly positioned to allow clearance when lowered, and transfer the pattern of the five access holes onto the finish piece.
6. Drill five through holes, with clearance for 3/8" bolts, in the finish piece and any cord management holes that may be necessary.
7. Place the finish piece on the shelf.
8. Place the plasma mounting assembly on top of the finish piece (see Figure 5).
9. Using a 5/16" Allen wrench inserted through the five access holes on the bottom of the shelf (see Figure 6), install five longer 3/8-16 cap screws.
10. With the aid of another person, lift the display up to the mount, aligning the PSB mounting buttons on the display with the teardrop slots on the mount, set the plasma into place and adjust mounting assembly to ensure proper clearance is achieved.
11. Measure and record clearance dimensions and, with the aid of another person, remove plasma.

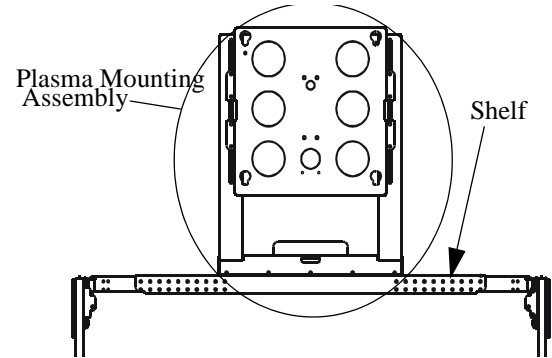

Figure 5. Plasma Mounting Assembly



Figure 6. Access Holes



WARNNG: Be aware during the installation that this is a motorized device, and there are pinch points for people and for electrical wiring. Keep hands and electrical wiring away from internal components of the mechanism

12. Carefully, without plasma mounted on lift, operate lift to ensure finish piece has sufficient clearance during full travel.

Retracted Position Finish Piece Option

A finish piece, covering the opening when the unit is retracted, may be installed for estetic purposes. Install the finish piece as follows:

1. Complete the instructions in "Extended Position Finish Piece Option" on page 6.
2. Cut two side pieces, matching the width of the extended position finish piece, to a length slightly longer than the distance the plasma will travel (this will be trimmed later).
3. Cut a top piece, matching the dimensions of your extended position finish piece (see Figure 7).

4. With the extended position finish piece and the plasma-mounted, lower the unit to its fully retracted position.
5. Place the side pieces in position (do not attach).
6. Place the top piece in position (do not attach).
7. Measure the distance from the top surface of the top piece to the top surface of your furniture and cut this dimension from each side piece (see Figure 8).
8. Remove and assemble finish pieces (bottom, sides and top), making sure your finished box is square.

CAUTION: A backing is recommended for support. Frame movement could result in damage to the frame, damage to the lift, and damage to the plasma.

CAUTION: Check plasma ventilation requirements. Provide ventilation for your application.

9. Measure box, construct a backing for lateral support, and install backing.

WARNNG: Be aware during the installation that this is a motorized device, and there are pinch points for people and for electrical wiring. Keep hands and electrical wiring away from internal components of the mechanism

CAUTION: Failure to allow clearance for the finish pieces to retract to the fully lowered position may result in damage to the finish pieces, damage to the lift, and damage to the plasma.



10. Carefully, without plasma mounted on lift, operate lift to ensure the finish pieces have sufficient clearance during full travel and that top finish piece is flush with the furniture top when fully retracted.

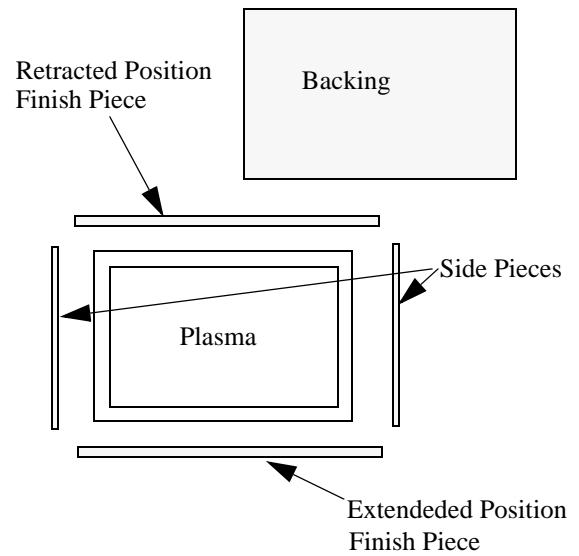

Figure 7. Retracted Position Finish Piece

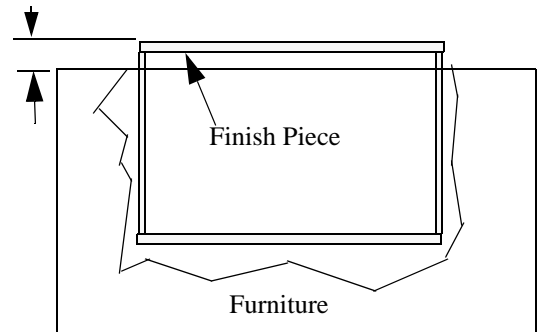

Figure 8. Side Piece Dimensions

Install the PUL into the Cabinet

1. Adjust motor/control box unit (see Figure 9).

NOTE: The motor/control box unit is factory set to the narrowest horizontal position.

- a. Loosen the six 5/16"-18X5/8" hex head bolts on the front of each half of the motor/control box and eight 1/4-20 socket head allen screws (4 front and 4 back) on the bracket mounting crossbrace. Slide both halves of the lift all the way in and out to ensure the lift can be adjusted freely.
- c. Measure the width of the inside enclosure where the lift will be mounted.
- d. Adjust the width of the lift, allowing for clearance, and hand tighten all bolts loosened in step a.

NOTE: The unit must be installed square and parallel in ALL dimensions for smooth and reliable operation. The extrusions housing the chains must also remain exactly square to the power box and parallel to each other after it has been installed. Shims may be required between the unit and the enclosure to maintain parallel dimensions between the extrusions.

2. Place the unit into the enclosure so the load to be lifted is centered over the vertical extrusion beams.
3. With the lift in place, use the base of the lift mechanism as a template to transfer 4 holes (17/64" diameter) to the enclosure bottom.

NOTE: If desired, you can use the additional four holes in the corners of the lift, but you must fill the space between the lift and enclosure bottom to prevent warping.

4. Remove the lift mechanism from the enclosure.
5. Drill the 4 holes (17/64" diameter) in the bottom of the enclosure.
6. Place the unit into the enclosure so the holes in the mechanism line up with the holes in the enclosure.
7. Secure the unit into the enclosure using 4 thru bolts (1/4-20 or larger), 8 fender washers, and 4 Nyloc nuts (see Figure 10). Tighten securely.

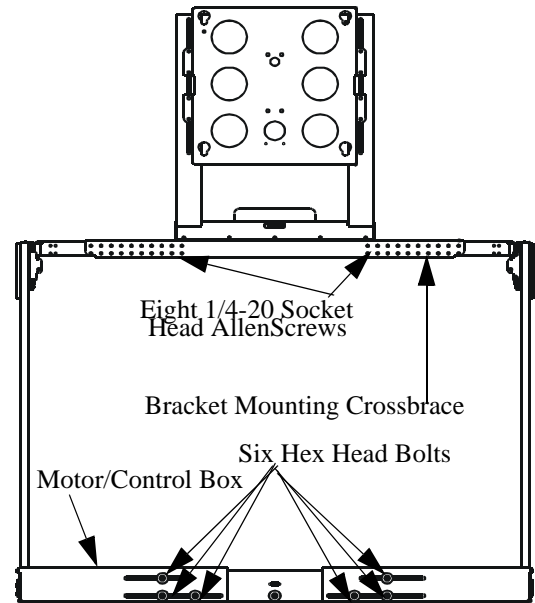

Figure 9. Motor/Control Box

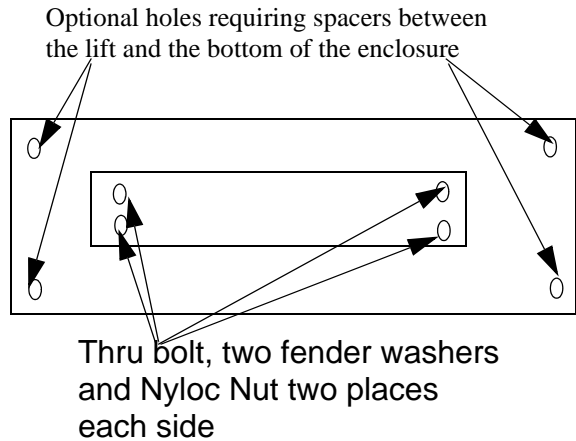

Figure 10. Secure Lift

INSTALL THE DISPLAY ON THE LIFT

Attach Brackets to the Display

1. Follow the instructions accompanying the PSB brackets designed for your display.

Mount the Display

1. Remove 4 screws and slide back panel cover up and out (see Figure 11).
2. Make sure the latch on the mount is lowered to the side before attempting to place the display on the mount (see Figure 12).
3. With the aid of another person, lift the display up to the mount, aligning the PSB mounting buttons on the display with the teardrop slots on the mount, and set the plasma into place.

CAUTION: If the latch does not travel to the full upright position, remove and reset the display.

4. While supporting the display, raise the latch.
5. Install Q-clamp (see Figure 13).
6. Install back panel cover and secure using 4 screws.

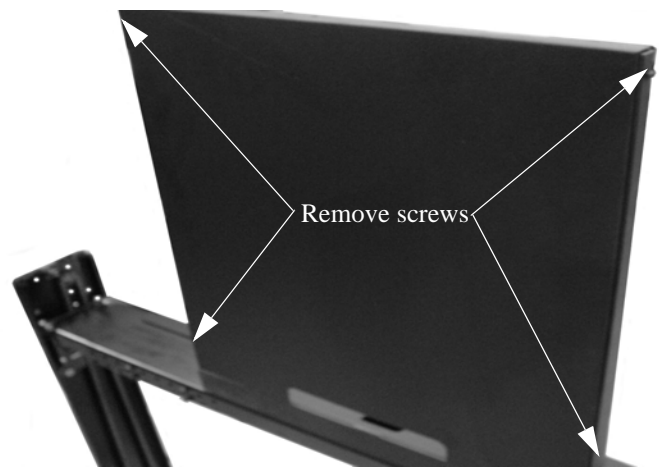

Figure 11. Back Panel Cover Removal

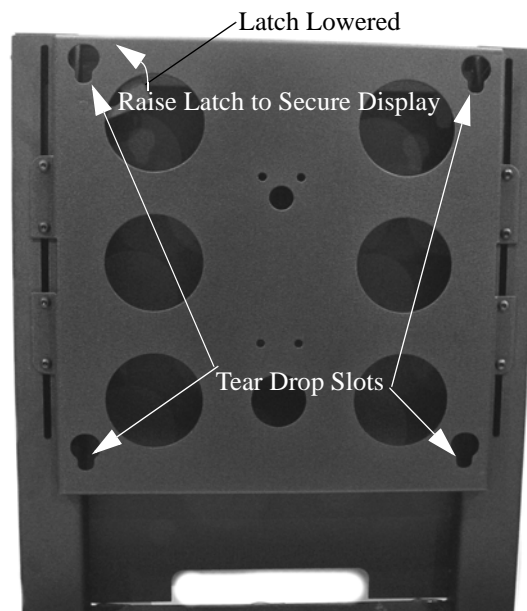

Figure 12. Latch and Tear Drop Slots

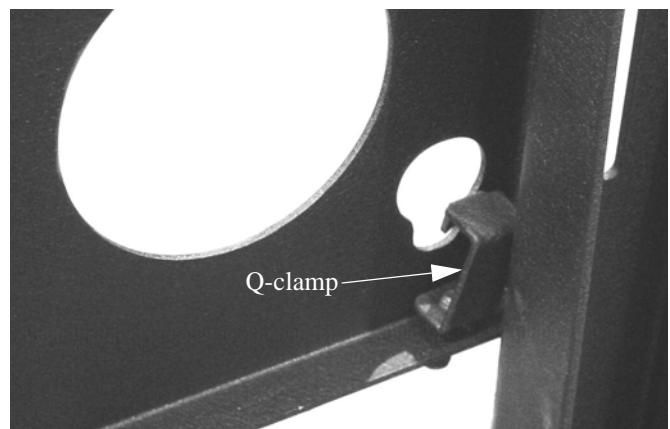

Figure 13. Install Q-clamp

ADJUSTMENTS



WARNING: Be aware during the installation that this is a motorized device, and there are pinch points for people and for electrical wiring.

Width Adjustment

Adjust width as follows (see Figure 14):

1. Loosen the six 5/16"-18X5/8" hex head bolts on the front of each half of the motor/control box and eight 1/4-20 socket head Allen screws (4 front and 4 back) on the bracket mounting crossbrace.
2. Slide the halves of the lift to the desired width and secure by tightening the bolts and socket head Allen screws loosened in Step 1.

Adjust Vertical Travel



WARNING: Be aware during the installation that this is a motorized device, and there are pinch points for people and for electrical wiring.

CAUTION: Vertical travel adjustment must always be made with the shelf in the middle of travel position and the power switch OFF.

There are two knobs for setting the travel limits, which are located at one end of the base controller housing (see Figure 15). The knob closest to the outside is the down stop limit adjustment. The knob closest to the center is the up stop limit adjustment

1. With the shelf in the middle of travel position and the power switch OFF, adjust the down limit to the desired height by turning the down stop adjustment knob (clockwise = higher position, counterclockwise = lower position).

CAUTION: The unit must always be able to reach its own limit switches and turn itself off.

2. Check to be sure the limit switch stops the unit and the unit is not being stopped due to interference.
3. With the shelf in the middle of travel position and the power switch OFF, adjust the up limit to the desired height by turning the down stop adjustment knob (clockwise = higher position, counterclockwise = lower position)

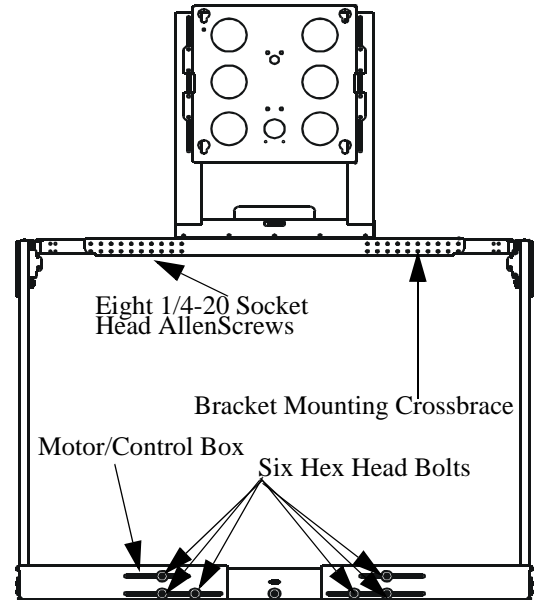

Figure 14. Width Adjustment

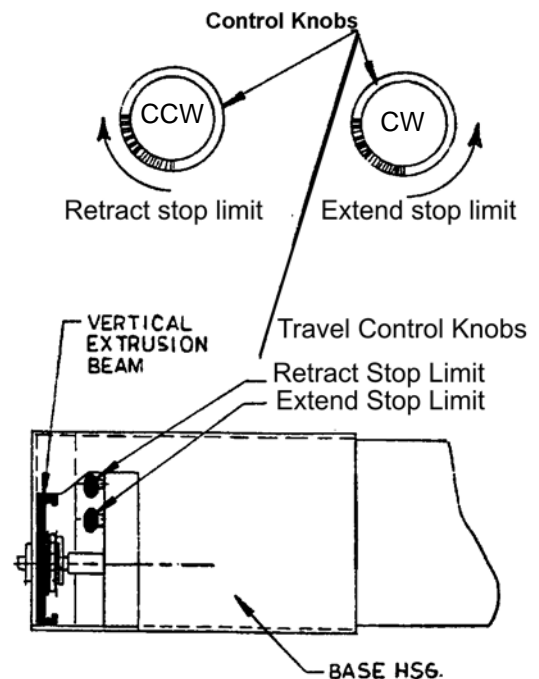

Figure 15. Vertical Travel Adjustment

THIS PAGE INTENTIONALLY BLANK

WIRING EXAMPLES

The information on the following pages cover the most common wiring options:

- Pushbutton
- Extend and Retract Terminals to be Triggered By Separate Dry Contacts
- Remote (RC-10)
- 12 Volt out supply
- 24 Volt out supply
- Two dry contact closures
- Voltage Sensing

Pushbutton

Wire for pushbutton operation as follows:

1. Install a wire between terminal 5 (extend/retract common) and ground terminal 3 (see Figure 16).
2. Connect one wire from pushbutton to terminal #4 (12 VDC power supply) and the other wire from the pushbutton to terminal #6 (extend/retract) (see Figure 17).

With the unit plugged in, push the button once and the unit should extend. Push the button during travel and the unit will stop at that location. Push the button after the unit is extended or stopped in mid-travel and the unit will retract.

Extend and Retract Terminals to be Triggered By Separate Dry Contacts

These terminals can be used with a wall switch or a separate set of dry contacts for dedicated extend and dedicated retract. Momentary contacts are preferable.

NOTE: The connection between the ground (#13) and any other terminal connection must be broken (open) before completing the next circuit.

1. Connect the common to terminal #13 (see Figure 18).
2. Connect the extend to terminal #11 (see Figure 19).
3. Connect the retract to terminal #12 (see Figure 20).

Completing the circuit between terminal #13 and terminal #11 will cause the unit to extend to the show position (see “Adjust Vertical Travel” on page 11 to change height setting). Completing the circuit between terminal #13 and terminal #12 will cause the unit to retract to the closed position.



Figure 16. 12 Volt Supply Jumper

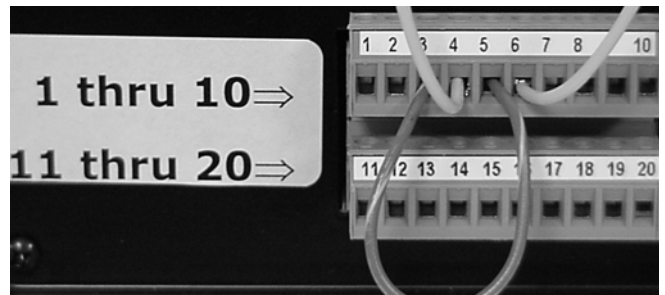

Figure 17. Pushbutton Wires

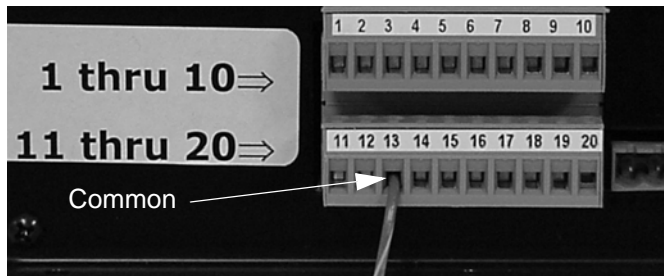

Figure 18. Common for Extend and Retract Contacts

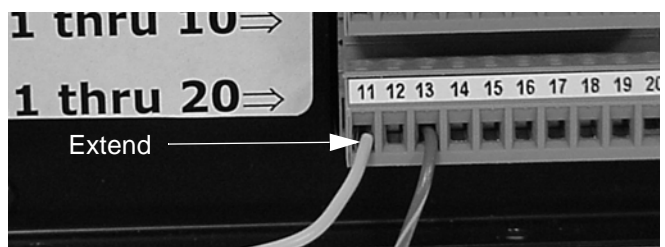

Figure 19. Extend Contact Wiring

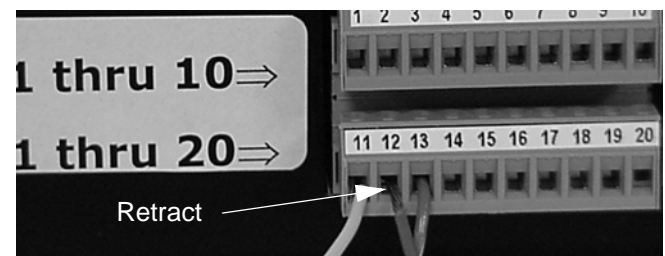

Figure 20. Retract Contact Wiring

THIS PAGE INTENTIONALLY BLANK

Remote (RC-10)

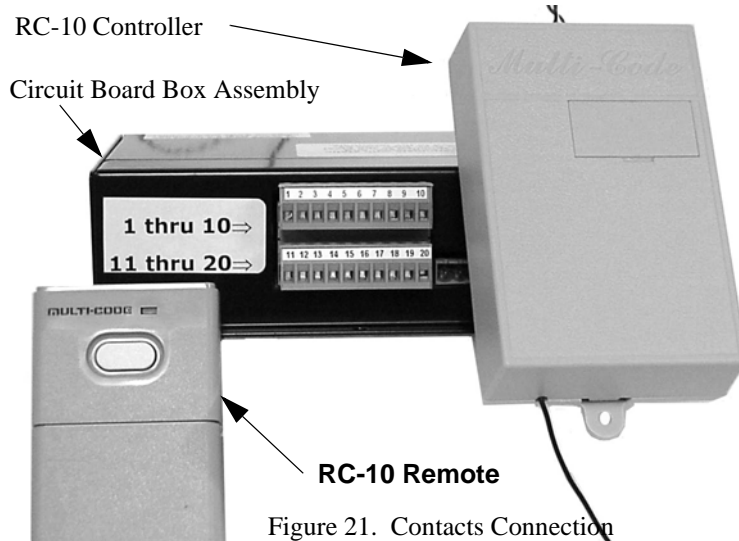

Figure 21. Contacts Connection

Wire for remote (RC-10) operation as follows (see Figure 21):

1. Install a jumper wire between terminals #6 and terminal #2 (see Figure 22).
2. Connect the white wire of the RC-10 controller unit to terminal #1 (see Figure 23).
3. Connect the red wire of the RC-10 controller unit to terminal #2.
4. Connect the black wire of the RC-10 controller unit to terminal #5.
5. Connect the power source to the lift.

NOTE: If the unit does not activate, check to make sure the 9 volt battery is working and make sure the dip switches in the sending unit match the dip switch settings in the controller unit (see Figure 24).

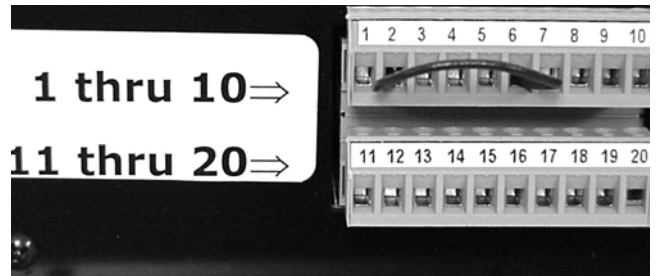

Figure 22. Contacts Connection

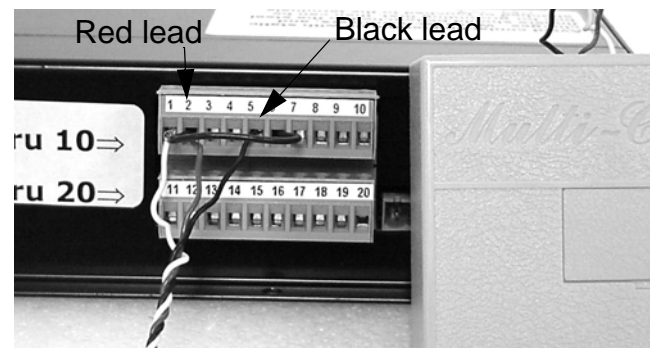

Figure 23. Contacts Connection

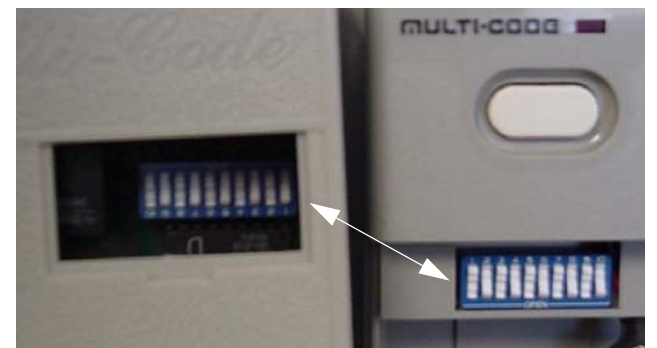

Figure 24. Dip Switches

THIS PAGE INTENTIONALLY BLANK

12 Volt Out Supply

This internal power supply can be used to power external devices &/or to initiate specific functions (see Pushbutton operation and Figure 25).

1. Connect one lead to 12 VOLT GROUND (terminal #9).
2. Connect one lead to 12 VOLTS OUT (terminal #10).

24 Volt Out Supply

This internal power supply can be used to power external devices & remote controllers (see Figure 26).

1. Connect one lead to 24 VOLT COMMON (terminal #2).
2. Connect one lead to 24 VOLTS OUT (terminal #1).

Two Dry Contact Closures

NOTE: Dry contacts are rated for 1 Amp @ 24 volts.

These contacts can be used to complete circuits to external devices (see Figure 27 and Figure 28).

1. Connect one lead to terminal #17 (extend limit common).
2. Connect one lead to terminal #16 (closes when unit reaches full extension).
3. Connect one lead to terminal #19 (retract limit common).
4. Connect one lead to terminal #18 (closes when unit is fully retracted).

Low Voltage Sensing

1. Connect positive lead (5 - 30 volts AC/DC) to terminal #7 and ground of switching device to terminal #8 (see Figure 29). Unit extends when voltage is sensed, retracts when voltage ceases.

Example using internal 12 volt DC supply (Figure 30):

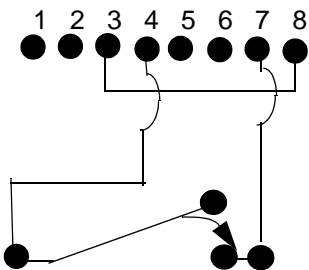

Figure 30. 12 Volt DC Supply

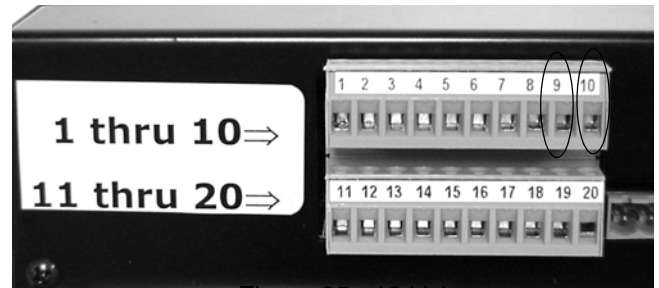

Figure 25. 12 Volts

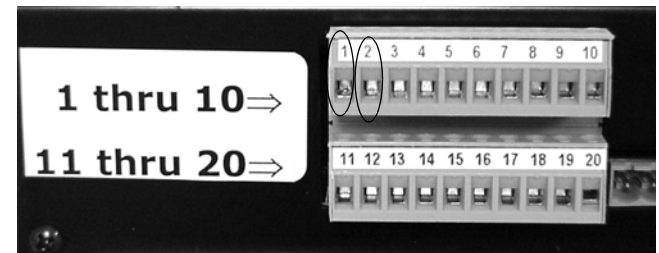

Figure 24. 26 Volts

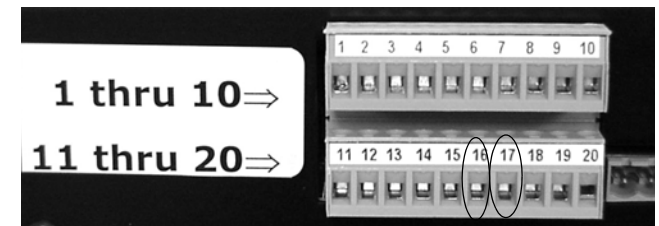

Figure 27. Extend Dry Contacts

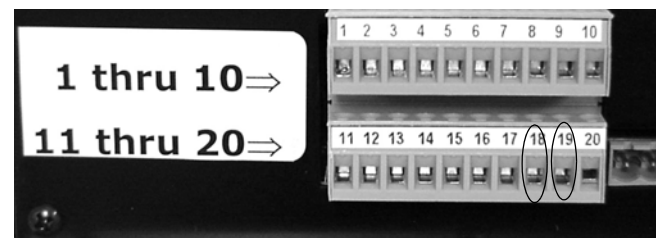

Figure 28. Retract Dry Contacts

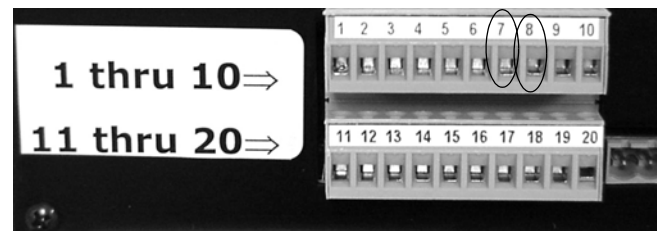

Figure 29. Low Voltage Sensing

THIS PAGE INTENTIONALLY BLANK

TROUBLESHOOTING

If the lift is installed according to these instructions, it should operate trouble-free indefinitely. If you do encounter a problem, and it isn't covered by the troubleshooting suggestions below, call the Technical Services Department at Chief Manufacturing:

1-800-582-6480

952-894-6280

Symptom(s)	Possible Causes	Suggested Action
No Movement and No Sound	No Power	1. Check power to unit (supply, cord, activation control, and connections). No power: Provide power, repair cord, tighten connections or repair activation control. Power: Check fuse on circuit board. If fuse is OK, proceed to next step.
	Faulty Circuit Board	2. Check circuit board as follows: Make three jumper wires with ends stripped. Install one jumper wire on terminal 11. Install one jumper wire on terminal 12. Install one jumper wire on terminal 13. Momentarily touch jumper wire from terminal 11 to terminal 13. Unit should extend. Momentarily touch jumper wire from terminal 12 to terminal 13. Unit should retract. Activates In both Directions: Circuit board OK, faulty activation interface. Check remote switch, circuit, or batteries in remote control. Unit Fails Both/Either Direction: Call Chief Manufacturing.
Unit Operates Noisily (Squeeling or grinding)	Track Misalignment	1. Check for noise and/or metal shavings in track Noise or Shavings: Check and adjust track and/or shelf as necessary. No Track Noise: Possible brake problem, call Chief Manufacturing

TERMINAL FUNCTION DEFINITIONS				
TERMINAL NUMBER	FUNCTION	DESCRIPTION	WIRING OPTIONS	NOTES
1	24 VOLT AC	24 volt AC output		This is an internal power supply for powering external devices & Remote Controllers.
2	24 VOLT AC COMMON	24 volt AC common		Chief Mfg. offers the RC-10 Radio Frequency Remote Controller which runs off of this power supply.
3	GROUND	Ground		This is an internal power supply for powering external devices &/or used for initiating specific functions (Extend/Retract 5 or Voltage Sensor 7).
4	12 VOLT DC	12 volt DC		
5	EXTEND/RETRACT	Initiates movement if lift is static, or stops movement if lift is in motion. Direction of travel will be opposite of last direction of travel.	<u>To Operate using Internal Power Source</u> Connect terminals 3 & 6 with Jumper Wire. Connect Momentary Switch to terminal 4. Connect other line of Momentary Switch to terminal 5.	Function operates on momentary switch only. Operating range is 5 – 30 Volts AC or DC
6	EXTEND/RETRACT COMMON	Used in conjunction with Extend/Retract when using an external power source to initiate movement.	<u>To Operate using External Power Source</u> Connect External Power Supply's Common to terminal 6. Connect initiating signal to terminal 5.	NOT TO BE USED AS GROUND FOR FUNCTION OTHER THAN EXTEND/RETRACT TERMINAL 5.
7	VOLTAGE SENSOR	When terminal senses voltage, unit will extend. When terminal senses cessation of voltage, unit will retract.	<u>Voltage Sensing</u> Connect positive lead to terminal 7. Connect Ground of switching device to terminal 8. <u>Single-Pull/Throw Latching Switch</u>	Operating range is 5 – 30 Volts AC or DC
8	VOLTAGE SENSOR COMMON	Used in conjunction with Voltage Sensor when using an external power source to initiate movement.	Connect terminals 3 & 8 with Jumper Wire. Connect first Switch Terminal to terminal 4. Connect other Switch Terminal to terminal 7.	NOT TO BE USED AS GROUND FOR FUNCTION OTHER THAN VOLTAGE SENSOR TERMINAL 7.
9	SERVICE EXTEND	Extends unit to maximum limit, bypassing normal-use travel setting. Often used for servicing projectors in ceiling lifts on PCL and MD models	Momentary or Latching contact to Ground terminals 3, 10, 13, or 20.	Feature not available on all models. If using Latching Switch, be sure to disengage Switch prior to initiating any other function.
10	GROUND	Ground		

11	EXTEND	Extends unit to preset travel limit. Customer within a preset maximum range may adjust travel limits.	Momentary or Latching contact to Ground terminals 3, 10, 13, or 20.	If using Latching Switch, be sure to disengage Switch prior to initiating any other function.
12	RETRACT	Retracts unit to preset travel limit. Travel limits may be adjusted by customer within a preset maximum range.		If using Latching Switch, be sure to disengage Switch prior to initiating any other function.
13	GROUND	Ground		
14	EXTEND ERROR	Immediately reverses direction of travel when triggered while unit is extending.	Momentary contact to Ground terminals 3, 10, 13, or 20.	Chief Mfg. offers the SS-10 Pressure Sensitive Safety Strip to provide this function. Please specify how many inches required spanning entire pinch zone. The SS-10 must be ordered with the ST-1: Terminals.
15	RETRACT ERROR	Immediately reverses direction of travel when triggered while unit is retracting.		
16	EXTEND LIMIT RELAY	Closes set of internal dry contacts when unit reaches full extension.		RATED FOR 1 AMP @ 24 VOLTS
17	EXTEND LIMIT RELAY COMMON			
18	RETRACT LIMIT RELAY	Closes set of internal dry contacts when unit reaches full retraction.		RATED FOR 1 AMP @ 24 VOLTS
19	RETRACT LIMIT RELAY COMMON			
20	GROUND	Ground		

WIRING THE RC-10

Connect white lead to terminal 1, red lead to terminal 2, and black lead to terminal 5.
Place jumper wire from terminal 2 to terminal 6

WIRING A MOMENTARY PUSH BUTTON

Connect terminals 3 & 6 with Jumper Wire. Connect Momentary Switch to terminal 4. Connect other line of Momentary Switch to terminal 5.